



The flexible capabilities of the Tyreflex Coupling help to accommodate angular, parallel and axial misalignments.

Parallel Misalignment upto 6 mm. Angular Misalignment upto 4°. End Float upto 8 mm. Suitable in ambient temp. upto 70°C.

### CUSHIONING SHOCK LOADS

Tyreflex being a torsionally soft coupling protects against vibration, impact loads and heavy shocks in the event of sudden load changes.

### EASE OF ASSEMBLY / DISASSEMBLY

Alignment is quickly checked by placing a straight edge across the outside diameters of the flanges.

Installation or replacement of new tyre is achieved without disturbing driver or driven shafts, simply by loosening the clamping screws, placing a new tyre between the flanges and clamping rings and then tightening the clamping screws.

### TYRE-FLEX COUPLING - RST

Tyre-flex Spacer Couplings RST are specifically designed for motor-pump installations, where it is desirable not to disturb drive/driven equipment while servicing impellers, packing glands, etc.

The maintenance time-reduction feature is valuable on pumps, compressors and many other applications.

It comprises of a spacer assembly and a standard Tyre-flex coupling. The spacer assembly consists of a flanged shaft and a spacer adapter taper bored to suit standard Taper Bush.

### SELECTION PROCEDURE - T/TO

#### (a) Service Factor

Determine the required service factor from table 1.

#### (b) Design Power

Multiply the normal running power by the service factor. This gives **Design Power** which is used as a basis for selecting the coupling.

#### (c) Coupling Size

Refer table 2 and from the appropriate speed read across until a power greater than that required is found. The size of Tyre-flex coupling required is given in that column..

#### (d) Bore Size

Check from table 3 that selected coupling can accommodate required bores.

### SELECTION PROCEDURE - RST

1. Select a suitable size of Tyre-flex coupling using the procedure.
2. Refer size column in table A and locate the size of coupling selected.
3. Read across this size until required DBSE can be accommodated.
4. The size of the spacer coupling is given in the first column of table A.
5. Refer coupling dimensional table A to check that the required bores can be accommodated.

**TABLE 1 : SERVICE FACTORS**

| SPECIAL CLASSES<br>For applications where substantial shock, vibration and torque fluctuations occur and for reciprocating machines e.g. internal combustion engines, piston pumps and compressors, refer to Rathi Transpower Pvt. Ltd. with full application details for analysis. | Type of Driving Unit              |                     |         |   |                     |         |
|---|-----------------------------------|---------------------|---------|---|---------------------|---------|
|   | Electric Motors<br>Steam Turbines |                     |         | Internal Combustion Engines<br>Steam Engines<br>Water Engines |                     |         |
|   | Hours per day duty                |                     |         | Hours per day duty  |                     |         |
| Type of Driven Machine  | upto 10                           | over 10 to 16 incl. | Over 16 | upto 10   | over 10 to 16 incl. | Over 16 |
| <b>CLASS 1</b><br>Agitators, Brewing machinery, Centrifugal compressors and pumps, Belt Conveyors, Dynamometers, Lineshafts, Fans upto 7.5 kW, Blower and exhausters ( except positive displacement ), Generators.  | 0.8                               | 0.9                 | 1.0     | 1.3   | 1.4                 | 1.5     |
| <b>CLASS 2</b><br>Clay working machinery, General machine tools, Paper mill beaters and winders, Rotary pumps, Rubber extruders, Rotary Screens, Textile Machinery, Marine Propellers, and Fans over 7.5 kW.  | 1.3                               | 1.4                 | 1.5     | 1.8   | 1.9                 | 2.0     |
| <b>CLASS 3</b><br>Bucket elevators, Cooling tower fans, Piston compressors & pumps, Foundry machinery, Metal presses, Paper mill Calenders, Hammer mills, Presses and pulp grinders, Rubber Calenders, Pulverisers and Positive displacement blowers.                               | 1.8                               | 1.9                 | 2.0     | 2.3   | 2.4                 | 2.5     |
| <b>CLASS 4</b><br>Reciprocating conveyors, Gyrotory crushers, Mills ( ball, pebble and rod ). Rubber Machinery ( Banbury Mixers and Mills ) and Vibratory screens.  | 2.3                               | 2.4                 | 2.5     | 2.8   | 2.9                 | 3.0     |

**TABLE 2: POWER RATING (kW)**

| Speed rpm | Size T / TO |       |       |       |         |         |        |        |        |         |         |        |      |       |      |
|-----------|-------------|-------|-------|-------|---------|---------|--------|--------|--------|---------|---------|--------|------|-------|------|
|           | 4           | 5     | 6     | 7     | 8       | 9       | 10     | 11     | 12     | 14      | 16      | 18     | 20   | 22    | 25   |
| 100       | 0.25        | 0.69  | 1.33  | 2.62  | 3.93    | 5.24    | 7.07   | 9.16   | 13.9   | 24.3    | 39.5    | 65.7   | 97.6 | 121   | 154  |
| 750       | 1.87        | 5.17  | 9.97  | 19.65 | 29.47   | 39.30   | 53.02  | 68.70  | 104.25 | 182.25  | 296.25  | 492.75 | 732  | 907.5 | 1155 |
| 1000      | 2.50        | 6.90  | 13.30 | 26.20 | 39.30   | 52.40   | 70.70  | 91.60  | 139.0  | 243.0   | 395.0   | 657.0  | 976  | 1215  | 1537 |
| 1500      | 3.75        | 10.35 | 19.95 | 39.30 | 58.95   | 78.60   | 106.05 | 137.40 | 208.50 | 364.50  | 592.50* | 986.5* | -    | -     | -    |
| 1800      | 4.50        | 12.42 | 23.94 | 47.16 | 70.74   | 94.32   | 127.26 | 164.88 | 250.20 | 437.40* | -       | -      | -    | -     | -    |
| 3000      | 7.50        | 20.70 | 39.90 | 78.60 | 117.90* | 157.20* | -      | -      | -      | -       | -       | -      | -    | -     | -    |
| 3600      | 9.00        | 24.84 | 47.98 | 94.32 | -       | -       | -      | -      | -      | -       | -       | -      | -    | -     | -    |

- All these power ratings are calculated at constant torque.
- For speeds below 100 rpm and intermediate speeds use normal torque ratings.
- \* Dynamic balancing preferred at these speeds.

|       |      |      |      |     |
|-------|------|------|------|-----|
| Poles | 2    | 4    | 6    | 8   |
| rpm   | 3000 | 1500 | 1000 | 750 |

**TECHNICAL DATA : FLEXIBLE TYRES**

| Size                        | 4    | 5    | 6    | 7    | 8    | 9    | 10   | 11   | 12   | 14   | 16   | 18    | 20    | 22    | 25    |
|-----------------------------|------|------|------|------|------|------|------|------|------|------|------|-------|-------|-------|-------|
| Max. Speed rpm              | 4500 | 4500 | 4000 | 3600 | 3100 | 3000 | 2600 | 2300 | 2050 | 1800 | 1600 | 1500  | 1300  | 1100  | 1000  |
| Torsional Stiffness Nm/Deg. | 5    | 13   | 26   | 41   | 63   | 91   | 126  | 178  | 296  | 470  | 778  | 1371  | 1959  | 2760  | 3562  |
| Parallel Misalignment mm    | 1.1  | 1.3  | 1.6  | 1.9  | 2.1  | 2.4  | 2.6  | 2.9  | 3.2  | 3.7  | 4.2  | 4.8   | 5.3   | 5.8   | 6.6   |
| End Float mm                | 1.3  | 1.7  | 2.0  | 2.3  | 2.6  | 3.0  | 3.3  | 3.7  | 4.0  | 4.6  | 5.3  | 6.0   | 6.6   | 7.3   | 8.2   |
| Normal Torque Nm            | 24   | 66   | 127  | 250  | 375  | 500  | 675  | 875  | 1330 | 2325 | 3730 | 6270  | 9325  | 11600 | 14675 |
| Max. Torque Nm              | 64   | 160  | 318  | 487  | 759  | 1096 | 1517 | 2137 | 3547 | 5642 | 9339 | 16455 | 23508 | 33125 | 42740 |

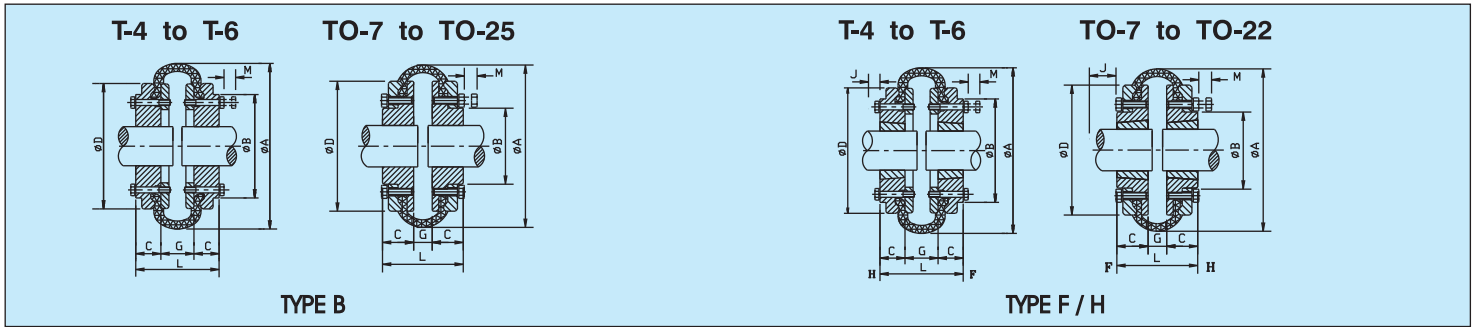
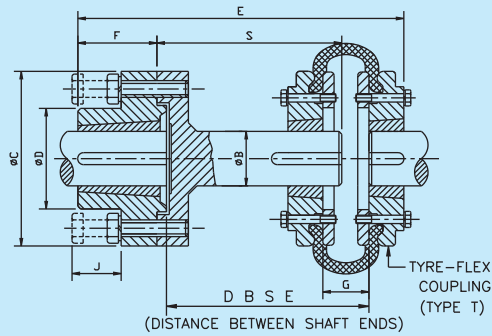

**TABLE 3 : DIMENSIONS OF TYRE-FLEX HUB TYPES B, F & H**

| Size  | Kw at 100 rpm | Max Speed rpm | Type | # Bush Size | # Bore |      | Type F/H |     |     | Type B |     | A   | D   | B   | M   | G  | Weight per Coupling kg. | Moment of Inertia (WR <sup>2</sup> ) per Coupling kgm <sup>2</sup> |         |        |
|-------|---------------|---------------|------|-------------|--------|------|----------|-----|-----|--------|-----|-----|-----|-----|-----|----|-------------------------|--|---------|--------|
|       |               |               |      |             | PB     | Max. | L        | C   | J   | L      | C   |     |     |     |     |    |                         |  |         |        |
|       |               |               |      |             |        |      |          |     |     |        |     |     |     |     |     |    |                         |  | Metric  | Inch   |
| T-4   | 0.25          | 4500          | B    | -           | 10     | 32   | 1 1/4    | -   | -   | -      | 65  | 22  | 104 | 82  | -   | 17 | 21                      | 1.9  | 0.00161 |        |
|       |               |               | F/H  | 1008        | -      | 25   | 1        | 65  | 22  | 29     | -   | -   |     |     |     |    |                         | 1.7  | 0.00148 |        |
| T-5   | 0.69          | 4500          | B    | -           | 10     | 38   | 1 1/2    | -   | -   | -      | 89  | 32  | 133 | 100 | 79  | 17 | 25                      | 3.5  | 0.00358 |        |
|       |               |               | F/H  | 1210        | -      | 32   | 1 1/4    | 75  | 25  | 38     | -   | -   |     |     |     |    |                         | 2.7  | 0.00349 |        |
| T-6   | 1.33          | 4000          | B    | -           | 15     | 45   | 1 3/4    | -   | -   | -      | 106 | 38  | 165 | 125 | 73  | 8  | 30                      | 5  | 0.0105  |        |
|       |               |               | F/H  | 1610        | -      | 42   | 1 5/8    | 80  | 25  | 38     | -   | -   |     |     |     |    |                         | 3.6  | 0.0103  |        |
| TO-7  | 2.62          | 3600          | B    | -           | 19     | 50   | 2        | -   | -   | -      | 106 | 45  | 197 | 144 | 82  | -  | 16                      | 8.4  | 0.0177  |        |
|       |               |               | F    | 2012        | -      | 50   | 2        | 80  | 32  | 38     | -   | -   |     |     |     |    |                         | 6.35   | 0.0192  |        |
|       |               |               | H    | 1610        | -      | 42   | 1 5/8    | 66  | 25  |        | -   | -   |     |     |     |    |                         | 9  | 6.2     | 0.0157 |
| TO-8  | 3.93          | 3100          | B    | -           | 25     | 63   | 2 1/2    | -   | -   | -      | 123 | 51  | 210 | 167 | 96  | 10 | 21                      | 11.5   | 0.0329  |        |
|       |               |               | F    | 2517        | -      | 60   | 2 1/2    | 111 | 45  | 42     | -   | -   |     |     |     |    |                         | 9  | 8.53    | 0.0303 |
|       |               |               | H    | 2012        | -      | 50   | 2        | 85  | 32  |        | -   | -   |     |     |     |    |                         | 8.5  | 0.0293  |        |
| TO-9  | 5.24          | 3000          | B    | -           | 30     | 75   | 3        | -   | -   | -      | 138 | 57  | 235 | 188 | 110 | -  | 24                      | 16   | 0.0599  |        |
|       |               |               | F/H  | 2517        | -      | 60   | 2 1/2    | 114 | 45  | 48     | -   | -   |     |     |     |    |                         | 12   | 0.0538  |        |
| TO-10 | 7.07          | 2600          | B    | -           | 32     | 80   | 3 1/8    | -   | -   | -      | 140 | 60  | 254 | 216 | 125 | -  | 20                      | 22.7   | 0.1148  |        |
|       |               |               | F    | 3020        | -      | 75   | 3        | 122 | 51  | 48     | -   | -   |     |     |     |    |                         | 18.2   | 0.1062  |        |
|       |               |               | H    | 2517        | -      | 60   | 2 1/2    | 110 | 45  |        | -   | -   |     |     |     |    |                         | 18.1   | 0.1058  |        |
| TO-11 | 9.16          | 2300          | B    | -           | 32     | 90   | 3 1/2    | -   | -   | -      | 151 | 65  | 279 | 233 | 140 | -  | 21                      | 28.3   | 0.1631  |        |
|       |               |               | F/H  | 3020        | -      | 75   | 3        | 123 | 51  | 55     | -   | -   |     |     |     |    |                         | 21.1   | 0.1461  |        |
| TO-12 | 13.9          | 2050          | B    | -           | 38     | 100  | 4        | -   | -   | -      | 177 | 76  | 314 | 264 | 152 | -  | 25                      | 40.1   | 0.2902  |        |
|       |               |               | F    | 3525        | -      | *100 | 4        | 155 | 65  | 55     | -   | -   |     |     |     |    |                         | 30.33  | 0.2627  |        |
|       |               |               | H    | 3020        | -      | 75   | 3        | 127 | 51  |        | -   | -   |     |     |     |    |                         | 30.3   | 0.2622  |        |
| TO-14 | 24.3          | 1800          | B    | -           | 58     | 127  | 5        | -   | -   | -      | 200 | 89  | 359 | 311 | 195 | 26 | 22                      | 60.6   | 0.6045  |        |
|       |               |               | F/H  | 3525        | -      | *100 | 4        | 152 | 65  | 67     | -   | -   |     |     |     |    |                         | 42.6   | 0.4922  |        |
| TO-16 | 39.5          | 1600          | B    | -           | 65     | 140  | 5 1/2    | -   | -   | -      | 212 | 102 | 395 | 345 | 216 | -  | 8                       | 86.4   | 1.2755  |        |
|       |               |               | F/H  | 4030        | -      | *115 | 4 1/2    | 162 | 77  | 80     | -   | -   |     |     |     |    |                         | 72.6   | 1.1134  |        |
| TO-18 | 65.7          | 1500          | B    | -           | 70     | 150  | 6        | -   | -   | -      | 254 | 116 | 470 | 398 | 220 | -  | 22                      | 133.3  | 2.1525  |        |
|       |               |               | F/H  | 4535        | -      | *125 | 5        | 200 | 89  | 89     | -   | -   |     |     |     |    |                         | 123.0  | 1.9514  |        |
| TO-20 | 97.6          | 1300          | B    | -           | 70     | 150  | 6        | -   | -   | -      | 258 | 114 | 508 | 429 | 220 | -  | 30                      | 144.6  | 3.1765  |        |
|       |               |               | F/H  | 4535        | -      | *125 | 5        | 208 | 89  | 89     | -   | -   |     |     |     |    |                         | 158.3  | 3.0129  |        |
| TO-22 | 121           | 1100          | B    | -           | 75     | 160  | 6 1/2    | -   | -   | -      | 281 | 127 | 562 | 470 | 240 | -  | 27                      | 181.63   | 4.7861  |        |
|       |               |               | F/H  | 5040        | -      | 125  | 5        | 231 | 102 | 92     | -   | -   |     |     |     |    |                         | 195.1  | 4.8954  |        |
| TO-25 | 154           | 1000          | B    | -           | 85     | 190  | 7 1/2    | -   | -   | -      | 294 | 132 | 628 | 532 | 275 | -  | 30                      | 281.1  | 8.129   |        |

- All dimensions are in mm unless otherwise specified.
- M is the amount by which clamping screws need to be withdrawn to release the tyre.
- J is the wrench clearance to allow for tightening and loosening the bush on the shaft.
- Shaft ends, although normally located G apart, can project beyond the flanges as shown. In this event allow sufficient space between shaft ends for end float and misalignment.
- Maximum torque figures should be regarded as short duration overload ratings for direct on line starting. Angular misalignment capacity up to 4°.
- Weights & Moment of Inertia specified are at without bores.
- # For detailed information about Taper Bush bore, please refer Taper Bush catalogue.
- \* Standard Bore 90mm, 100mm, 115mm & Max Bore with shallow key 100mm, 115mm & 125mm for bush nos. 3525, 4030 & 4535 respectively.

### T-4 to T-6



### TO-7 to TO-14

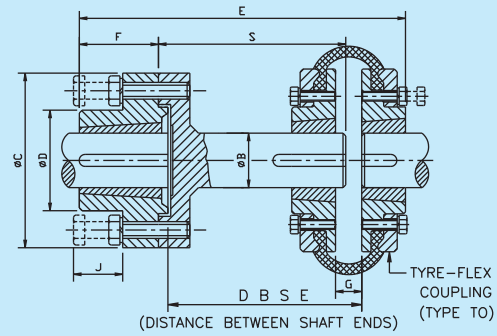

**TABLE A : DIMENSIONAL DATA**

| Spacer Size | Nom DBSE | Bush |             |       | ØC  | ØD  | E   |     | F  | J  | S   |     | ØB | Tyre-Flex Size T/TO | Bush |             |       | G  |    |
|-------------|----------|------|-------------|-------|-----|-----|-----|-----|----|----|-----|-----|----|---------------------|------|-------------|-------|----|----|
|             |          | Size | # Max. Bore |       |     |     | T   | TO  |    |    | T   | TO  |    |                     | Size | # Max. Bore |       | T  | TO |
|             |          |      | mm          | Inch  |     |     |     |     |    |    |     |     |    |                     |      | mm          | Inch  |    |    |
| RST 12      | 80       | 1210 | 32          | 1 1/4 | 118 | 83  | 130 | —   | 25 | 22 | 57  | —   | 25 | 4                   | 1008 | 25          | 1     | 21 | —  |
|             | 100      | 1210 | 32          | 1 1/4 | 118 | 83  | 150 | —   | 25 | 22 | 77  | —   | 25 | 4                   | 1008 | 25          | 1     | 21 | —  |
| RST 16      | 100      | 1615 | 42          | 1 5/8 | 127 | 80  | 163 | —   | 38 | 24 | 94  | —   | 32 | 4*                  | 1008 | 25          | 1     | 21 | —  |
|             | 140      | 1615 | 42          | 1 5/8 | 127 | 80  | 203 | —   | 38 | 24 | 134 | —   | 32 | 4*                  | 1008 | 25          | 1     | 21 | —  |
|             | 100      | 1615 | 42          | 1 5/8 | 127 | 80  | 166 | —   | 38 | 24 | 94  | —   | 32 | 5                   | 1210 | 32          | 1 1/4 | 25 | —  |
|             | 140      | 1615 | 42          | 1 5/8 | 127 | 80  | 206 | —   | 38 | 24 | 134 | —   | 32 | 5                   | 1210 | 32          | 1 1/4 | 25 | —  |
|             | 100      | 1615 | 42          | 1 5/8 | 127 | 80  | 166 | —   | 38 | 24 | 94  | —   | 32 | 6                   | 1610 | 42          | 1 5/8 | 30 | —  |
|             | 140      | 1615 | 42          | 1 5/8 | 127 | 80  | 206 | —   | 38 | 24 | 134 | —   | 32 | 6                   | 1610 | 42          | 1 5/8 | 30 | —  |
| RST 25      | 100      | 2517 | 60          | 2 1/2 | 178 | 127 | —   | 180 | 45 | 27 | —   | 94  | 48 | 7F                  | 2012 | 50          | 2     | —  | 16 |
|             | 140      | 2517 | 60          | 2 1/2 | 178 | 127 | —   | 220 | 45 | 27 | —   | 134 | 48 | 7F                  | 2012 | 50          | 2     | —  | 16 |
|             | 180      | 2517 | 60          | 2 1/2 | 178 | 127 | —   | 260 | 45 | 27 | —   | 174 | 48 | 7F                  | 2012 | 50          | 2     | —  | 16 |
|             | 100      | 2517 | 60          | 2 1/2 | 178 | 127 | —   | 193 | 45 | 27 | —   | 94  | 48 | 8F                  | 2517 | 60          | 2 1/2 | —  | 21 |
|             | 140      | 2517 | 60          | 2 1/2 | 178 | 127 | —   | 233 | 45 | 27 | —   | 134 | 48 | 8F                  | 2517 | 60          | 2 1/2 | —  | 21 |
|             | 180      | 2517 | 60          | 2 1/2 | 178 | 127 | —   | 273 | 45 | 27 | —   | 174 | 48 | 8F                  | 2517 | 60          | 2 1/2 | —  | 21 |
| RST 30      | 140      | 3030 | 75          | 3     | 216 | 146 | —   | 270 | 76 | 33 | —   | 134 | 60 | 10F                 | 3020 | 75          | 3     | —  | 20 |
|             | 180      | 3030 | 75          | 3     | 216 | 146 | —   | 310 | 76 | 33 | —   | 174 | 60 | 10F                 | 3020 | 75          | 3     | —  | 20 |
|             | 140      | 3030 | 75          | 3     | 216 | 146 | —   | 270 | 76 | 33 | —   | 134 | 60 | 11                  | 3020 | 75          | 3     | —  | 21 |
|             | 180      | 3030 | 75          | 3     | 216 | 146 | —   | 310 | 76 | 33 | —   | 174 | 60 | 11                  | 3020 | 75          | 3     | —  | 21 |
| RST 35      | 140      | 3535 | 90          | 3 1/2 | 248 | 178 | —   | 297 | 89 | 33 | —   | 134 | 80 | 12F                 | 3525 | 100         | 4     | —  | 25 |
|             | 180      | 3535 | 90          | 3 1/2 | 248 | 178 | —   | 337 | 89 | 33 | —   | 174 | 80 | 12F                 | 3525 | 100         | 4     | —  | 25 |
|             | 140      | 3535 | 90          | 3 1/2 | 248 | 178 | —   | 297 | 89 | 33 | —   | 134 | 80 | 14                  | 3525 | 100         | 4     | —  | 22 |
|             | 180      | 3535 | 90          | 3 1/2 | 248 | 178 | —   | 337 | 89 | 33 | —   | 174 | 80 | 14                  | 3525 | 100         | 4     | —  | 22 |

\* T4 'B' flange must be used to fit spacer shaft.

# For detailed information about Taper Bush bore, please refer Taper Bush catalogue.

● All dimensions are in mm unless otherwise specified.

**TABLE B: DISTANCE BETWEEN SHAFT ENDS (DBSE)**

| Tyre-flex Size T/TO | RST12 |     | RST 16 |     |     |     | RST 25 |     |     |     |     |     | RST 30 |     |     |     | RST 35 |     |     |     |
|---------------------|-------|-----|--------|-----|-----|-----|--------|-----|-----|-----|-----|-----|--------|-----|-----|-----|--------|-----|-----|-----|
|                     | 80    |     | 100    |     | 140 |     | 100    |     | 140 |     | 180 |     | 140    |     | 180 |     | 140    |     | 180 |     |
|                     | Min   | Max | Min    | Max | Min | Max | Min    | Max | Min | Max | Min | Max | Min    | Max | Min | Max | Min    | Max | Min | Max |
| 4                   | 80    | 100 | 100    | 113 | 140 | 153 |        |     |     |     |     |     |        |     |     |     |        |     |     |     |
| 5                   |       |     | 100    | 116 | 140 | 156 |        |     |     |     |     |     |        |     |     |     |        |     |     |     |
| 6                   |       |     | 100    | 124 | 140 | 164 |        |     |     |     |     |     |        |     |     |     |        |     |     |     |
| 7 F                 |       |     |        |     |     |     | 100    | 107 | 140 | 147 | 180 | 187 |        |     |     |     |        |     |     |     |
| 8 F                 |       |     |        |     |     |     | 100    | 112 | 140 | 152 | 180 | 192 |        |     |     |     |        |     |     |     |
| 9                   |       |     |        |     |     |     |        |     | 140 | 155 | 180 | 195 |        |     |     |     |        |     |     |     |
| 10 F                |       |     |        |     |     |     |        |     |     |     |     |     | 140    | 151 | 180 | 191 |        |     |     |     |
| 11                  |       |     |        |     |     |     |        |     |     |     |     |     | 140    | 151 | 180 | 192 |        |     |     |     |
| 12 F                |       |     |        |     |     |     |        |     |     |     |     |     |        |     |     |     | 140    | 156 | 180 | 196 |
| 14                  |       |     |        |     |     |     |        |     |     |     |     |     |        |     |     |     | 140    | 153 | 180 | 193 |

- Notes : ● Non-standard spacers are available on request.  
● Ref. installation instructions for mounting and dismantling.

In view of our constant endeavour to improve quality of our products, we reserve the right to alter or change specifications without prior notice. This document is the intellectual property of Rathi Transpower Pvt. Ltd. and subject to copyright.



### Rathi Transpower Pvt Ltd

Rathi Chambers, 7, Deccan College Road,  
Pune 411 006.(INDIA)  
Phone : 91-20-30517201  
Fax : 91-20-30517212  
E-mail : enquiry@rathigroup.com  
Website : www.rathicouplings.com

Distributor